

¿Cómo es?

















At school you see many different types of people. Describe each person you see in the picture by writing the appropriate adjective on the corresponding blank.



© Pearson Education, Inc. All rights reserved.

Un juego de descripción

Each picture below represents a personality trait. Unscramble the word to identify each trait. Write down the trait, and then circle the picture that corresponds to the unscrambled word.

- | | | | | |
|----|---|---|-------------|-------|
| 1. |  |  | ísiattcar | _____ |
| 2. |  |  | rvoidate | _____ |
| 3. |  |  | ddonaesdreo | _____ |
| 4. |  |  | jadartobaar | _____ |
| 5. |  |  | iacoarsg | _____ |
| 6. |  |  | zeerosap | _____ |
| 7. |  |  | vesrdoaer | _____ |
| 8. |  |  | utoiesdas | _____ |

¿Cómo eres?

Tito is interviewing Jorge and Ana, two new students from Costa Rica. Tito's questions are written below, but most of Jorge's and Ana's answers are missing. Complete their answers, using the model to help you.

Modelo TITO: Ana, ¿eres perezosa?

ANA: No, no soy perezosa.

1. TITO: Jorge, ¿eres talentoso?

JORGE: Sí, _____.

2. TITO: Ana, ¿eres estudiosa?

ANA: Sí, _____.

3. TITO: Jorge, ¿eres desordenado?

JORGE: No, _____.

4. TITO: Ana, ¿eres deportista?

ANA: No, _____.

5. TITO: Jorge, ¿eres sociable?

JORGE: Sí, _____.

6. TITO: Ana, ¿eres paciente?

ANA: No, _____.

7. TITO: Jorge, ¿eres inteligente?

JORGE: Sí, _____.

8. TITO: Ana, ¿eres artística?

ANA: No, _____.



¿Qué les gusta?

Based on what each person likes to do, write a description of him or her. Follow the model.

Modelo A Roberto le gusta esquiar.

Roberto es atrevido. _____

1. A Esteban le gusta tocar la guitarra.

2. A Pedro le gusta hablar por teléfono.

3. A Claudia le gusta practicar deportes.

4. A Teresa le gusta estudiar.

5. A Luz no le gusta trabajar.

6. A Manuela le gusta ir a la escuela.

7. A Carmen le gusta pasar tiempo con amigos.

8. A Lucía le gusta dibujar.

Me gusta . . .

Some new exchange students at your school are introducing themselves. Using the model as a guide, fill in the blanks in their statements with the actions and adjectives suggested by the pictures. Do not forget to use the correct (masculine or feminine) form of the adjective.

Modelo



A mí me gusta leer _____.

Yo soy inteligente _____.

1.



A mí _____.

Yo _____.

2.



A mí _____.

Yo _____.

3.



A mí _____.

Yo _____.

4.



A mí _____.

Yo _____.

5.



A mí _____.

Yo _____.

6.



A mí _____.







Yo _____.



¿Un o una?

A. Look at the drawings below and decide if they represent masculine or feminine words. Then, label the item in the space provided. Don't forget to use the appropriate indefinite article (**un** or **una**).







Modelo  un profesor

- | | |
|---|--|
| 1.  _____ | 4.  _____ |
| 2.  _____ | 5.  _____ |
| 3.  _____ | 6.  _____ |

B. Now, look at the drawings below and describe each person. Make sure to use all the words from the word bank. Don't forget to use the correct definite article (**el** or **la**) and to make the adjectives agree with the nouns.

estudiante	familia	chico	chica	profesor	profesora
------------	---------	-------	-------	----------	-----------

Modelo  La estudiante
es trabajadora.

- | | |
|--|---|
| 1.  _____ | 4.  _____ |
| 2.  _____ | 5.  _____ |
| 3.  _____ | 6.  _____ |

© Pearson Education, Inc. All rights reserved.



Oraciones completas

Choose sentence parts from each of the word banks below, then put them in the correct order to form complete sentences. Follow the model.

<p>Subjects:</p> <p>Marta Yo El Sr. Brown Rolando La Srta. Moley Tú</p>	<p>Verbs:</p> <p>es soy eres</p>
<p>Indefinite articles + nouns:</p> <p>un estudiante una estudiante un chico un profesor una chica una profesora</p>	<p>Adjectives:</p> <p>reservado(a) deportista inteligente estudioso(a) perezoso(a) bueno(a)</p>

Modelo Yo soy un chico estudioso. _____

1. _____
2. _____
3. _____
4. _____
5. _____
6. _____
7. _____
8. _____
9. _____
10. _____

© Pearson Education, Inc. All rights reserved.

Repaso

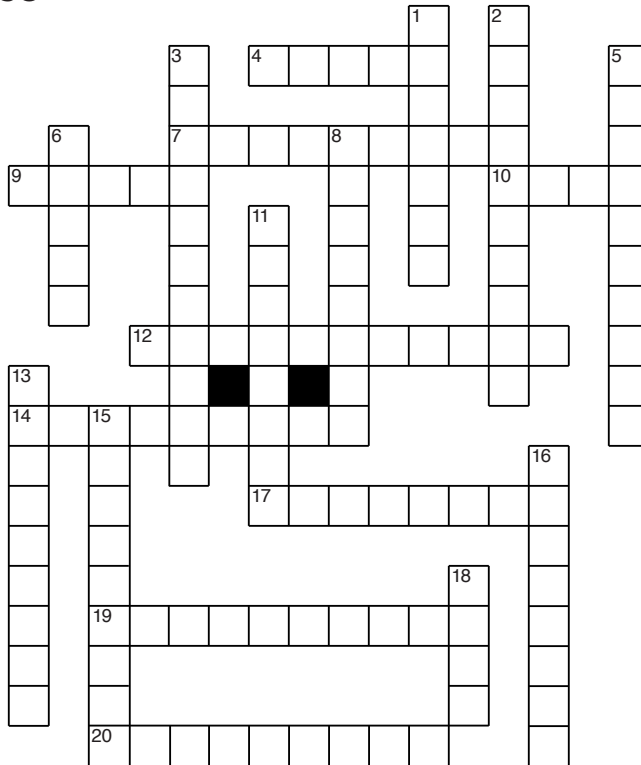

Down _____

1. según mi ____
2. no paciente
3. no ordenado
5. Un chico/una chica que practica deportes es ____.
6. *I like:* "Me ____."

Across _____



7. *nice, friendly*

9. no es malo, es ____

10. ¿____ se llama?



12.



14.



17.



19.



20.



8.

11. No es trabajador.
Es ____.



13.



15.

16. Le gusta pasar tiempo con amigos. Es ____.

18. —¿Cómo ____?

—Soy sociable.